





Trajectory Tracking and Formation Control of Mobile Robots Using Fuzzy Logic Controller with Obstacle Avoidance

Seyedeh Mahsa Zakipour Bahambari , Saeed Khankalantary * 

Department of Electrical Engineering, K.N. Toosi University of Technology, Tehran, Iran.

ABSTRACT: In various industries, the coordinated movements of mobile robots in triangular formations hold promise for enhancing efficiency and safety. This study investigates trajectory tracking and formation control using two distinct methodologies: the PID controller and the Fuzzy Logic Controller (FLC). Under ideal conditions, both controllers exhibit precise navigation and formation maintenance. Notably, the leader robot has a simulated virtual sensor for obstacle avoidance. The followers emulate the leader's path using the selected controller methodology. However, when exposed to external disturbances, modeled as sinusoidal waves, the FLC, with its superior adaptability and resilience, demonstrates its potential as a robust solution for real-world applications susceptible to disturbances. This research emphasizes the pivotal role of controller selection in practical scenarios and reiterates the FLC's potential, instilling confidence in its effectiveness.

Review History:

Received: Jun. 07, 2024

Revised: Dec. 03, 2024

Accepted: Dec. 18, 2024

Available Online: Dec. 18, 2024

Keywords:

Mobile-Robots

PID Controller

Fuzzy Logic Controller

Formation Control

Disturbance

1- Introduction

Mobile robots play a crucial role in various aspects of modern life, being intelligent machines that aid in tasks across industries like medicine, military, and household services. Their ability to operate in risky environments inaccessible to humans is a significant advantage. Motion control is a key focus in robotic research, ensuring robots can navigate safely from point A to point B without collisions. Designing mobile robotic platforms is complex and involves stages like platform design, motor sizing, control algorithm development, modeling, and verification, all while considering the system's time variance and the changing operational parameters and environment. Motion control, categorized into navigation, path following, and trajectory tracking, is a critical aspect of mobile robot design, necessitating robust and adaptive control algorithms for improved performance in dynamic and steady-state conditions[1]. DC motor-driven mobile robots are prevalent because DC motors offer easy controllability and exhibit linear characteristics in response to increased DC voltage[2]. Using the PWM (Pulse Width Modulation) technique, the robot receives a signal to drive a DC motor at a specific speed. However, the robot's speed may decrease when encountering a load or traveling uphill, increasing rapidly when descending downhill[3]. Research on PID controllers is

a challenging and highly active area that draws the attention of many scientists. Over the years, numerous methods and approaches have been explored. A recent development involves the creation of an optimal robust PID controller using the future search algorithm, specifically designed for systems with uncertain parameters. This innovative approach addresses uncertain systems' complexities, offering improved performance and stability[4]. An alternative approach, based on the bacterial foraging optimization algorithm, is effectively utilized to determine the optimized parameters of a PI controller for application in electrical grid systems. This approach outperforms the classical genetic algorithm approach, providing superior performance in optimizing the controller parameters for enhanced system operation[5]. A novel approach based on fuzzy sliding mode control was developed to address the design of a shipper controller for energy management without resorting to expensive classical solutions. This innovative method aims to regulate the frequency output within its limits and ensure system stability, particularly for systems characterized by uncertainties. By employing fuzzy sliding mode control, the controller can effectively adapt to varying conditions and uncertainties, offering a cost-effective and reliable solution for energy management in shipper systems[6]. Nonlinearity has been a prominent topic of discussion in numerous papers, with various control methods employed to address it. One such

*Corresponding author's email: s.kalantary@kntu.ac.ir



method involves utilizing improved neural network control systems to tackle nonlinearity, particularly in the context of robotic manipulators. This approach leverages the capabilities of neural networks to model and adapt to complex nonlinear dynamics, enhancing the control and performance of robotic manipulator systems[7]. Controlling nonlinear systems presents challenges addressed by various approaches, including fuzzy logic controllers and fuzzy-PID controllers. While conventional control methods like PID controllers are widely used in industrial settings due to their reliability and simplicity, they may exhibit reduced performance when applied to nonlinear systems. PID controllers can achieve stability and tracking, but their accuracy may be compromised, especially in nonlinear environments. As an alternative, fuzzy logic controllers (FLCs) have recently gained popularity. Based on artificial fuzzy logic algorithms, these controllers offer solutions for motion-related challenges in diverse applications, such as path planning, local and global navigation, steering control, and rate control in mobile robotics[8]. In the literature, a method employing fuzzy control techniques is utilized to ensure stability in the attitude of a quadcopter UAV. This approach focuses on maintaining the desired values for crucial parameters such as the roll angle, pitch angle, and yaw angle of the UAV. The system can adapt to varying conditions and disturbances by employing fuzzy control, ensuring precise control over the UAV's attitude and enhancing stability[9]. These autonomous machines have transformed how we perceive automation and efficiency. One aspect of mobile robots is their ability to operate in formations, enabling coordinated movements and collective decision-making[10]. Mobile robots are self-contained machines with sensors, processors, and actuators, allowing them to move and interact with their environment without constant human intervention. They come in various forms, such as small ground-based robots designed for specific applications. Formation control focuses on coordinating multiple robots to work together in an organized manner[10]. This research, with its innovative approach to trajectory tracking and formation control, will pique professionals' interest in robotics and control systems.

This capability opens up various possibilities across different industries, enhancing efficiency, safety, and cost-effectiveness in multiple tasks. One of the most prominent applications of mobile robots in formation lies in sectors like logistics and warehousing[11, 12]. In these settings, fleets of robots collaborate to transport goods, optimize warehouse layouts, and minimize order fulfillment time. The ability of robots to communicate and adapt their formations to changing environments ensures streamlined operations with reduced human involvement. In agriculture, mobile robots operating in formation can enhance crop growth. Coordinated teams of robotic vehicles can perform tasks such as planting, harvesting, and monitoring crops with accepted precision. They can cover large areas efficiently by working together, increasing agricultural productivity, and reducing resource waste[13, 14]. Search and rescue operations also benefit from mobile robots operating in formations. In disaster-stricken

areas, teams of ground robots can collaboratively explore hazardous environments, locate survivors, and transmit critical data back to rescue teams[15, 16]. Their ability to cooperate with information allows them to cover extensive areas and enhance the success rate of these missions while reducing the risks to human responders. Moreover, mobile robots in formation find applications in infrastructure inspection[17] and environmental monitoring[18]. Whether inspecting bridges and pipelines or monitoring pollution levels in remote regions. While the concept of mobile robots operating in formation holds promise, there are challenges to overcome. These include developing advanced algorithms for decentralized decision-making, ensuring reliable communication between robots, and addressing safety concerns when dealing with large, interconnected fleets. Formation in mobile robots refers to the coordinated arrangement of multiple robots to achieve a specific task or objective. These robots work collectively while maintaining relative positions and orientations concerning each other. Inspired by natural systems like flocks of birds and swarms of insects, formation in mobile robots can range from simple geometric patterns to intricate configurations used in various applications such as search and rescue, surveillance, and exploration. There are several ways to achieve formation in mobile robots, each offering unique benefits for different scenarios. One method involves leader-follower formation[10], where one robot assumes the role of a leader, and others follow its movements, adjusting their positions accordingly. Another approach employs virtual structures[19], where a desired formation shape is defined, and each robot aligns itself with this virtual structure. The potential field method also assigns attractive and repulsive possible fields to desired positions and obstacles, allowing robots to navigate toward places while avoiding collisions[20]. Decentralized control enables each robot to make decisions based on local information, interacting with neighboring robots to achieve consensus on their movements and maintain the formation[21]. Inspired by social insects, swarm intelligence algorithms enable local robot interactions to achieve emergent global behaviors[22]. Vision-based formation uses cameras or sensors to track other robots' positions, allowing each robot to adjust its position and orientation to maintain the desired formation[23]. The formation of the multi-robot system is a cooperative behavior of the interacting mobile robots sharing one goal[24]. The leader-follower formation problem has been analyzed by considering several control strategies, mainly using the feedback linearization approach[25]. In addition, backstepping strategies have been implemented in the solution of the leader-follower problem; for example, in[26], the leader-follower formation is assured using Cartesian coordinates to avoid singularities that appear in polar coordinates.

To control the operation and stability of the Mobile Robot during tracking trajectories, this paper aims to model the Mobile Robot and design a PID and Fuzzy controller system with a manual tuning method as the base controlling system of the mobile robot. The contributions of this work are

summarized as follows:

A mathematical model of the mobile robot is designed.

A PID and Fuzzy controller are designed to achieve stabilization and track the trajectories.

Formation emulates the leader's trajectory.

These mobile robots and the virtual sensor are simulated in MATLAB Simulink and tested in a virtual environment with obstacles.

The structure of this paper is outlined as follows: Section 1 describes the mathematical model of the Mobile Robot, while Section 2 presents the controllers then, and Section 3 provides formation control with Obstacle-Avoidance for the leader robot in multi-agent robots. Section 4 provides the simulations that substantiate the paper's objectives. Lastly, the concluding remarks are shown in the final section.

2- KINEMATICS OF Mobile- ROBOT

2- 1- Motion Mode

Consider an inertial reference frame denoted as x_i, x_y , and a robot frame denoted as x_R, y_R . The robot's position $p = [x, y, \theta]$ is given in the Cartesian coordinate system of the inertial frame. The relationship between the inertial frame and the robot frame is represented by a fundamental transformation matrix as follows:

$$\begin{aligned} \dot{e}_r &= R(\theta)\dot{e}_i \\ &= R(\theta) \cdot [\dot{x}, \dot{y}, \dot{\theta}]^T \\ R(\theta) &= \begin{pmatrix} \cos \theta & \sin \theta & 0 \\ -\sin \theta & \cos \theta & 0 \\ 0 & 0 & 1 \end{pmatrix} \end{aligned} \quad (1)$$

This robot is a two-wheeled differential drive robot, meaning that each wheel is powered by its own motor. When both wheels are driven at the same speed, forward motion is accomplished; to turn right, the left wheel must move faster than the right, and vice versa for turning left. With one wheel moving ahead and the other wheel moving at the same speed in the opposite direction, this kind of mobile robot can spin on the spot. A mobile robot requires a castor wheel as its third wheel to maintain stability. In addition to facilitating movement, each wheel places restrictions on the robot's range of motion. It's expected that the robot's wheels won't slip. It is expressed as a Non-Holonomic Constraint.

$$\dot{x} \sin \theta - \dot{y} \cos \theta = 0 \quad (2)$$

Instead of robot driving and steering velocities x and w , the real robot motion commands are the angular velocities ω_R and ω_L of the left and right wheels, respectively. First, take into account how much each wheel's spinning speed contributes to the translation speed in the $+X_R$ direction. P will move instantly at half the speed if one wheel rotates while the other wheel does not move and remains stationary.

This is because P is halfway between the two wheels. The v_x of a differential drive robot can be computed by adding these two contributions. Think about a differential robot, for instance, where the wheels rotate in opposite directions at the same speed. The end product is a rotating, stationary robot. Will be 0 in this instance, as predicted.

$$\omega_2 = -\frac{r}{d} \omega_L \quad (3)$$

Mapping between Robot velocities and wheel velocities is given as follows:

$$\begin{aligned} v &= r \left(\frac{\omega_R + \omega_L}{2} \right) \\ \omega &= r \left(\frac{\omega_R - \omega_L}{2} \right) \end{aligned} \quad (4)$$

Where, $r = \text{radius}$ of wheel and $d = \text{axial distance between wheels}$.

2- 2- Kinematic Equations

The most fundamental study of the behavior of mechanical systems is kinematics. In order to construct mobile robots that are suitable for desired tasks and to know how to create control software, we in mobile robotics must comprehend the mechanical behavior of the robot.

The combined action of the angular and linear velocities controls the coordinate system of the robot. The robot cartesian, assuming geometrical assumptions, is given by:

$$\begin{aligned} \dot{x} &= v \cos(\phi) \\ \dot{y} &= v \sin(\phi) \\ \dot{\theta} &= \frac{r}{L} (\omega_R - \omega_L) \end{aligned} \quad (5)$$

Where $v \cos(\phi)$ and $v \sin(\phi)$ are the components of v along its x and Y axes and x, y and orientation θ are measured concerning the reference Inertial Frame.

In this case, the output of the kinematic section is as follows P_x, P_y, ϕ_z , and at the end of this plant, all of these are named $Q = [P_x, P_y, \phi_z]$ in Figure 1. Present the Nonholonomic Wheeled Mobile Robot.

3- CONTROL ALGORITHM DESIGN

In this section, the PID control of the mobile robot is investigated first. Then a fuzzy logic controller is used for position control of all mobile robots. Finally, we use a formation algorithm for trajectory tracking with obstacle avoidance.

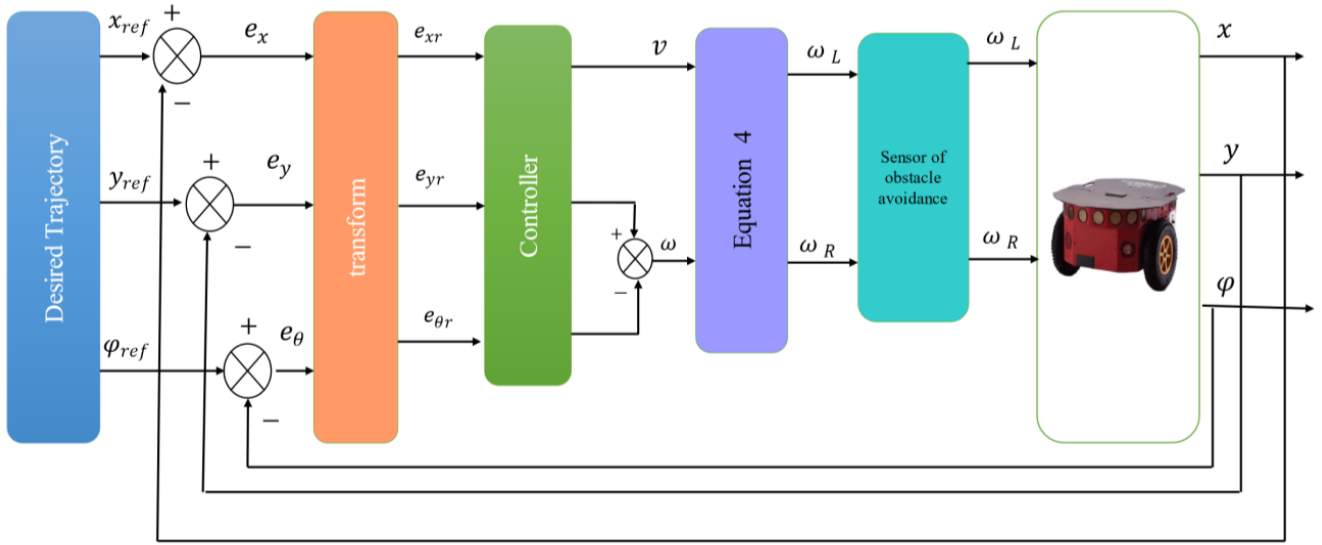

Fig. 1. Nonholonomic Wheeled Mobile Robot

3- 1- PID-Controller

The linear model of a Mobile Robot can be efficiently controlled by implementing a PID controller tuned using the Ziegler-Nichols rules. This can be further enhanced by incorporating parameter feedback linearization for elements influencing the Mobile Robot's position. The utilization of a PID controller offers several key advantages, including its straightforward control architecture and ease of implementation. By leveraging these techniques, precise control over the Mobile Robot's position can be achieved, enhancing its overall performance and stability[27].

A PID controller is designed for each follower to follow the leader's trajectory while maintaining a specific formation. The error signal is represented as shown in [23] for each error component, namely e_x , e_y and e_θ a separate PID controller is designed[19].

$$\begin{bmatrix} e_{xr}(t) \\ e_{yr}(t) \\ e_{\theta r}(t) \end{bmatrix} = \begin{bmatrix} \cos(\phi(t)) & \sin(\phi(t)) & 0 \\ \sin(\phi(t)) & \cos(\phi(t)) & 0 \\ 0 & 0 & 1 \end{bmatrix} \times (q_{ref}(t) - q(t)) \quad (6)$$

These PID controllers enable the mobile robots to adjust their linear and angular velocities to follow the leader's path accurately. The in Equation (6) is the current position of the mobile robot, and $q_{ref}(t)$ is the desired position. And $q_{ref}(t) - q(t) = [e_x, e_y, e_\theta]^T$. The followers can use the PID controllers' error signals to regulate their motion and maintain the desired formation concerning the leader's trajectory. This

control mechanism allows the followers to dynamically adjust their velocities to match the leader's movements, ensuring effective and coordinated motion within the formation. Also Figure 2. shows the general process of the PID-Control method in mobile robots. The coefficients in Equation (7) must be determined to design the PID controller.

$$u(t) = K_p e(t) + K_i \int_0^t e(t) dt + K_d \frac{de(t)}{dt} \quad (7)$$

3- 2- Fuzzy Logic Controller:

Fuzzy Logic Controllers offer an alternative to PID controllers in mobile robot control. Instead of relying on precise mathematical models, FLCs use fuzzy sets and linguistic rules to handle uncertainty and imprecision[28, 29]. Inputs and outputs will be defined and processed through fuzzy rules, capturing knowledge about how the robot should respond. Fuzzy inference generates control signals, allowing the robot to adapt to complex and dynamic environments. FLC offers a practical control approach for effective navigation and formation maintenance when precise modeling is challenging.

To apply the Fuzzy Mamdani controller to the system, the calculation of error and derivative error is carried out, and these values serve as inputs to the FLC. Linear and angular velocity are determined as outputs by the FLC. In the FLC design process, seven Gaussian membership functions have been set for each input, namely, error and change error, Figure 3. shows this process. The membership functions for each input are displayed in Figure 4. Additionally, seven membership functions have been defined for the output,

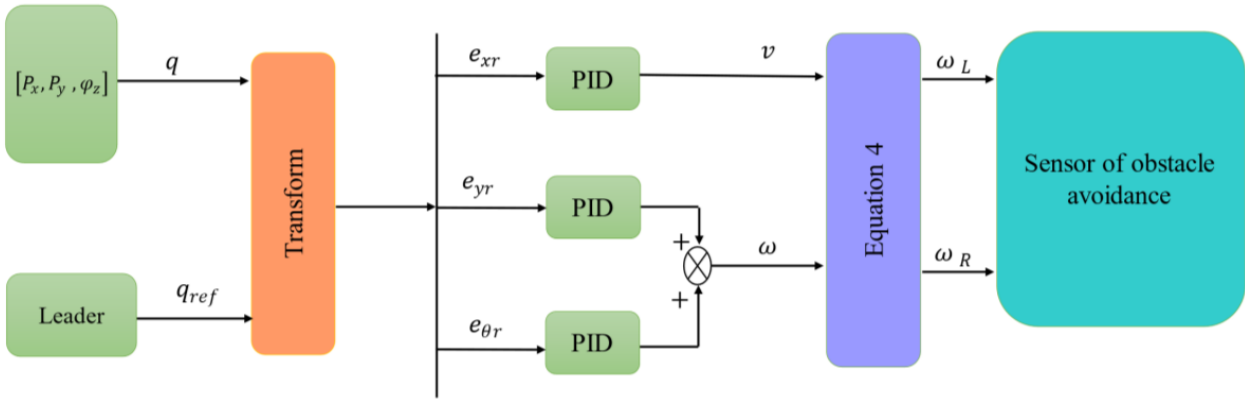

Fig. 2. The complete architecture of the PID-Controller for Mobile Robot

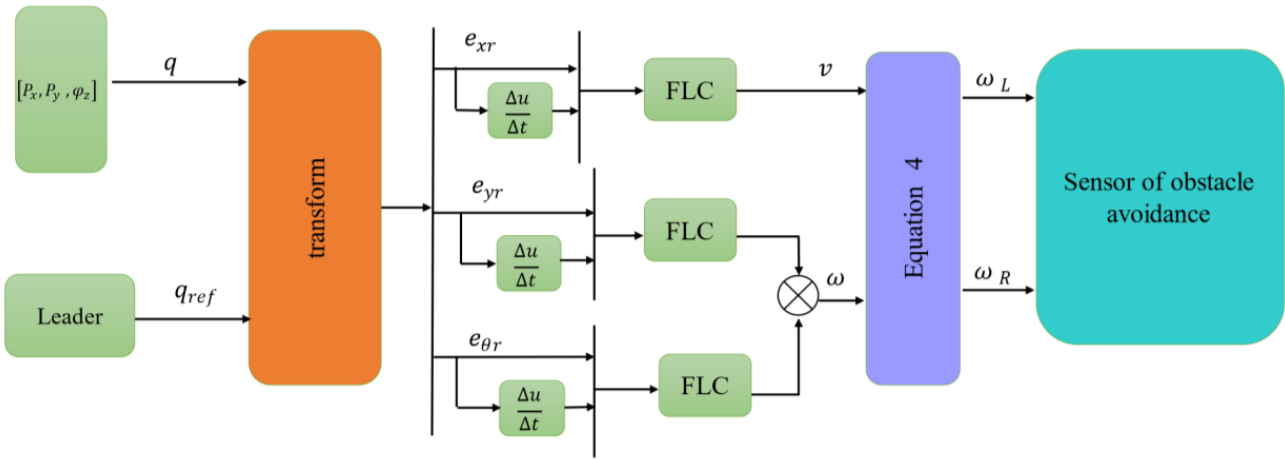

Fig. 3. Complete architecture of the Fuzzy-Controller for Mobile-Robot

as depicted in Figure 5. Fuzzy rules have been formulated following the establishment of input and output membership functions. Given the presence of two inputs, each consisting of seven membership functions, 49 rules have been generated. These rules are presented in Table 1.

4- Formation Control with Obstacle Avoidance for the Leader Robot

Building on the methodology described in [1], we define a formation as a tuple $f = (S, G)$, where G is a control graph that shows the control strategies of individual robots and their dependencies on other robots and S is a set of shape variables that define the formation structure. The shape variables include robot separations and relative bearings. The purpose of control rules is to maintain a follower's relative heading and separation from its leader (also known as separation-bearing control or SBC) or the follower's separations from

two leaders (also known as separation-separation control or SSC). As a result, each robot's control method, shape variables, and leaders can be specified to create formations.

Definition 1 (Control Graph): A control graph is represented as a directed, acyclic graph, where in each robot i defines a vertex. A directed edge from robot j to robot i implies that the robot j acts as a local leader to robot i , i.e., robot i maintains its position concerning the robot j . Similar to [1], we impose specific constraints on the control graph:

The formation leader, denoted as must not have any incoming edges and should have at least one outgoing edge.

All other robots must have at least one incoming edge and no more than two incoming edges. If a robot has exactly one incoming edge, it adopts the SBC strategy; otherwise, it adopts the SSC strategy if it has two incoming edges. Robots with three or more incoming edges are considered over-constrained for planar formations and are not permitted.

Table 1. Fuzzy inference rules

		Error							
Error Rate	NB	NB	NM	NS	ZE	PS	PM	PB	
	NM	NB	NB	NB	NB	NB	NM	NS	ZE
	NS	NB	NB	NB	NM	NS	ZE	PS	PM
	ZE	NB	NM	NS	ZE	PS	PM	PB	PB
	PS	NM	NS	ZE	PS	PM	PB	PB	
	PM	NS	ZE	PS	PM	PB	PB	PB	
	PB	ZE	PS	PM	PB	PB	PB	PB	

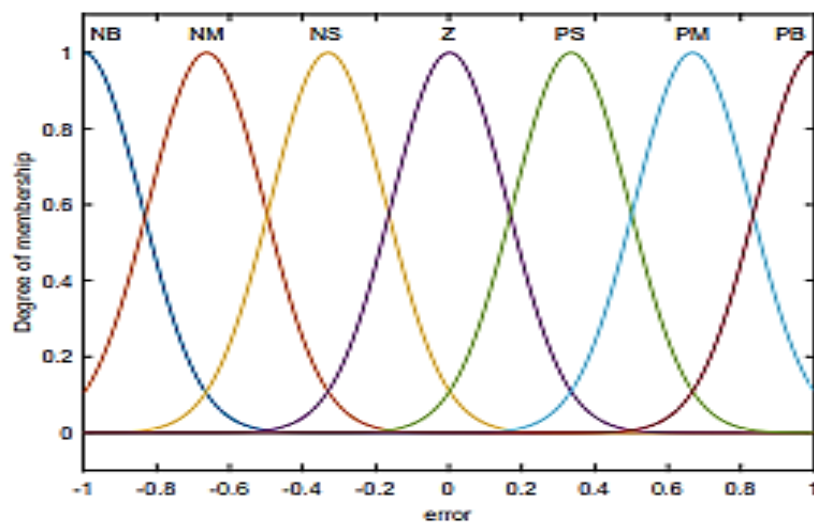

Fig. 4. Input membership for error and error change

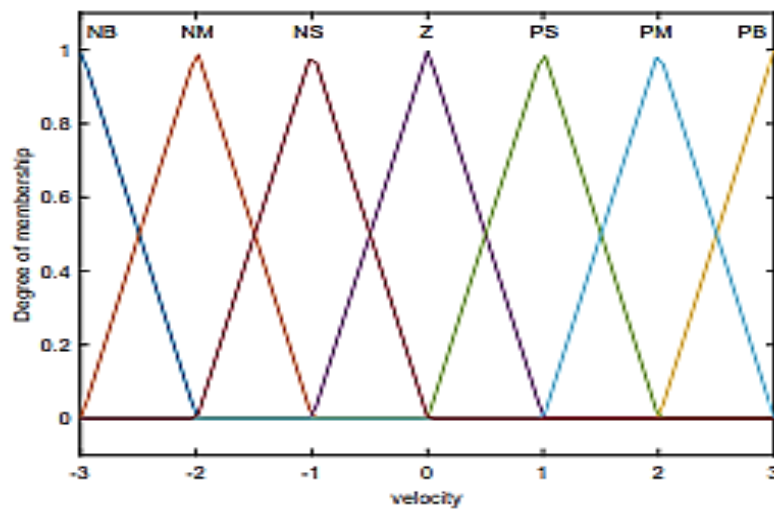

Fig. 5. Output membership function for velocity

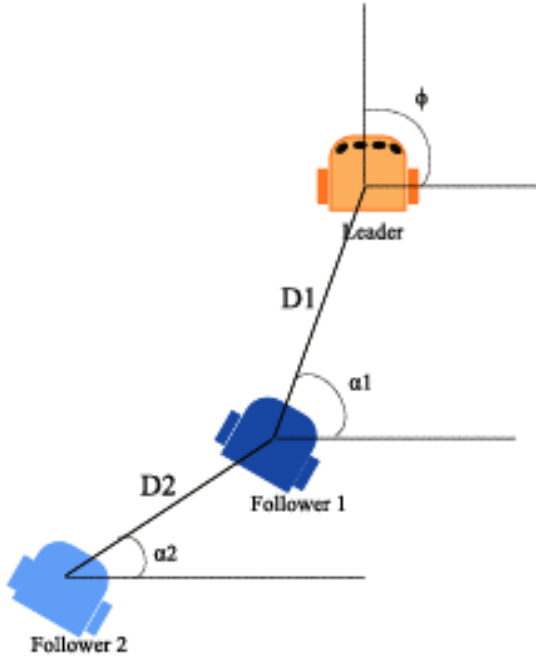

Fig. 6. Mobile robot model and leader-following formation[19]

Future intelligent transportation systems will likely include autonomous wheeled vehicles. A key application is automated vehicle platooning on highways, where vehicles can autonomously drive in a virtual train formation. In such a platoon, vehicles must precisely and safely follow their leader with minimal safety distance, thereby increasing highway capacity, preventing traffic jams, and enhancing safety. This exercise involves designing a control algorithm for mobile robots to drive in a linear formation. Achieving precise automated driving formations requires advanced sensor systems to measure global information like GPS data, or relative information like distance and bearing, or both. Here, we will implement a decentralized control strategy that relies solely on a relative sensor—a laser range finder (LRF). Each vehicle uses its LRF to measure the distance and azimuth to the vehicle ahead. This information is then used to track the leader's path. The leading vehicle's path is recorded in the local coordinates of the follower using odometry and LRF measurements (distance (D) and azimuth (α)). As illustrated in Figure 6, the follower vehicles then use trajectory tracking control to follow the estimated paths of their leader vehicles.

It is well known that robot localization using odometry is prone to accumulating various errors, such as wheel slip, sensor noise, and actuator noise. Consequently, odometry is only reliable for short-term localization. However, as shown later, the absolute pose error from odometry is not critical in linear formation control because the essential factor is the relative position (D) and (α) between vehicles. This relative position is accurately measured using the LRF, and

only short-term odometry localization is needed to estimate the part of the leader's path that the follower must soon drive.

4- 1- Localization Using Odometry

Odometry is the most straightforward localization approach where integration of the robot kinematic model at known velocities of the robot obtains the pose estimate. If differential robot velocities change at discrete time instants $t = kT_s, k = 0, 1, 2, \dots$ where T_s is the sampling interval, then the next robot pose is obtained from the current pose and the current velocities:

$$x(k+1) = x(k) + v(k)T_s \cos(\phi(k))$$

$$y(k+1) = y(k) + v(k)T_s \sin(\phi(k)) \quad (8)$$

$$\phi(k+1) = \phi(k) + \omega(k)T_s$$

Where:

$$v_k T_s = \Delta s$$

$$\omega_k T_s = \Delta \theta \quad (9)$$

$$T_s = t_{k+1} - t_k$$

Given the current robot pose in global coordinates obtained through odometry, the robot can determine the location of the leader robot using the known relative position between them. This relative position is obtained from LRF measurements, which provide the distance (D) and azimuth (α) to the leader. The main concept is to record the leader's positions, estimate the leader's trajectory, and have the follower robot use this trajectory as a reference to follow. Thus, the leader's position is estimated as follows for Follower 1 and Follower 2.

$$q_{ref} = q_{ref}(1) + D \cos \phi q_{ref}(1) + \alpha \quad (10)$$

$$q_{ref} = q_{ref}(2) + D \cos \phi q_{ref}(2) + \alpha$$

A control tracking error is computed considering the follower's actual posture $(x(t_0), y(t_0), \phi(t_0))$ and its reference posture $(x_{ref}(t_0), y_{ref}(t_0), \phi_{ref}(t_0))$ using Equation (10).

The leading robot is equipped with a virtual sonar sensor, which is simulated using MATLAB Simulink for obstacle avoidance. The sonar sensor array consists of eight sensors strategically placed before the mobile robot. A binary map of the environment representing obstacles and walls is provided to the sensor to facilitate obstacle detection. A map sample is

shown in Figure 7. The sonar sensor continuously measures distances to potential obstacles as the robot navigates through the environment.

When the sensor detects an obstacle within its range, the robot employs Algorithm 1 to adjust its path and avoid collisions. The algorithm assesses the distances measured by each sonar sensor and determines if any indicate an obstacle within proximity. Suppose an obstacle is found to be closer than the range of any individual sensor. In that case, the algorithm calculates a new trajectory for the robot to safely maneuver around the detected obstacle.

The equation computes the leader's current position (x, y, ϕ) And calculates the desired position for each follower. Subsequently, the followers use a controller to adjust their velocity and approach the leader. The formation parameters are illustrated in Figure 6. for a more detailed understanding. The sensor-based controller for the robot navigation profile is defined according to the following algorithm (Algorithm 1).

The sensor-based controller algorithm for a three-wheeled mobile robot adjusts the wheel speeds based on sensor inputs to ensure obstacle avoidance and efficient navigation. Initially, the speed limit v is set to 1. The algorithm runs in a loop until the simulation time is reached. It checks sensors positioned around the robot: if sensors 4 and 5 detect a front obstacle, the robot turns by reversing the right wheel and moving the left wheel forward. If sensors 2 and 3 detect a left-front obstacle, the right wheel moves very slowly forward while the left wheel moves normally, causing a slight right turn. Similarly, if sensors 6 and 7 detect a right-front obstacle, the robot turns slightly left. For side obstacles detected by sensors 1 and 8, the robot adjusts by turning right or left, respectively. If no obstacles are detected, both wheels move forward at speed v . This continuous adjustment based on sensor readings allows the robot to navigate autonomously and avoid obstacles effectively.

Algorithm 1 Sensor-based controller for robot navigation

```

v ← 1
while time < SimTime do
  if Sensor (4,5) < Range(4,5) then
    ωR = -v
    ωL = v
  else if Sensor (2,3) < Range(2,3) then
    ωR = v/5
    ωL = v
  else if Sensor (6,7) < Range(6,7) then
    ωR = v
    ωL = v/5
  else if Sensor (1) < Range(1) then
    ωR = v/2
    ωL = v
  else if Sensor (8) < Range(8) then
    ωR = v
    ωL = v/2
  else
    ωR = ωL = v
  end if
end while

```

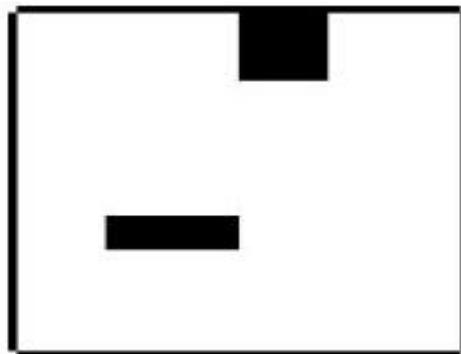

Fig. 7. A sample binary map of the environment

Table 2. Physical parameters of Mobile-Robot

symbol	Description and unit	value
I	Distance between right and left wheel	036m
I_V	Moment of inertia around	0.4732 kg. m^2
c	Viscous friction factor	0.15833kg/s
m	Mass of Mobile-Robot	24kg
I_w	Moment of inertia of the wheel	0.0198 kg. m^2
k	Driving gain factor	1.7
I_m	Moment of inertia of each driving wheel with a motor about the wheel diameter	0.0025 kg. m^2
R	Armature winding resistance	0.033m
L	Armature winding inductance	0.16m
k_e	Back emf constant	0.19 rad/s
k_m	Torque constant	0.2613 N.m/A
N	Gear ratio	62.55

5- Simulation and Resules

This section investigates three scenarios involving various modes of PID and Fuzzy controllers, considering their performance with and without disturbances. It explores the behavior of the Fuzzy controller under differing disturbance conditions. Additionally, Table 2. presents the constant values employed in simulating the mobile robot.

5- 1- The First Scenario: PID controller without Disturbance

Without external disturbances, the PID controller effectively controls the mobile robots. It reduces errors in the x and y dimensions, allowing the robots to follow the leader's trajectory with minimal deviations. Orientation

errors are also well-regulated. Figure 8. illustrates the PID error of the two follower mobile robots while tracking the leader's trajectory. Moreover, the Mean Square Error (MSE) for each follower's orientation is calculated. It is $MSE\phi_1=0.0395$, $MSE\phi_2=0.0032$. The navigation performance is characterized by smooth path tracking, the desired triangular formation maintenance, and obstacle avoidance. The navigation of mobile robots and the triangle formation is illustrated in Figure 9. This figure shows that the leader can move in the environment without hitting obstacles, and the followers can follow it well. Using this approach, we determined the PID gain parameters in Table 3.

Table 3. Parameter of PID Gain

	KP	KI	KD
x	1.1	3.3	0.2
y	1.1	3.3	0.2
ϕ	1.1	3.3	0.2

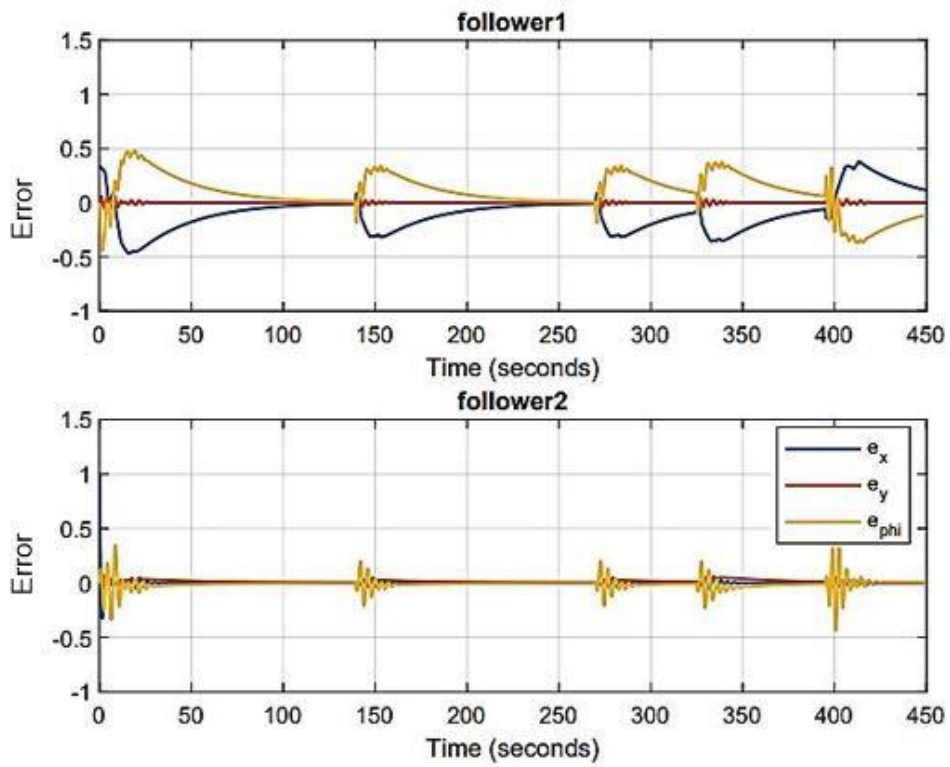

Fig. 8. Position and orientation errors for follower mobile robots with PID without disturbance

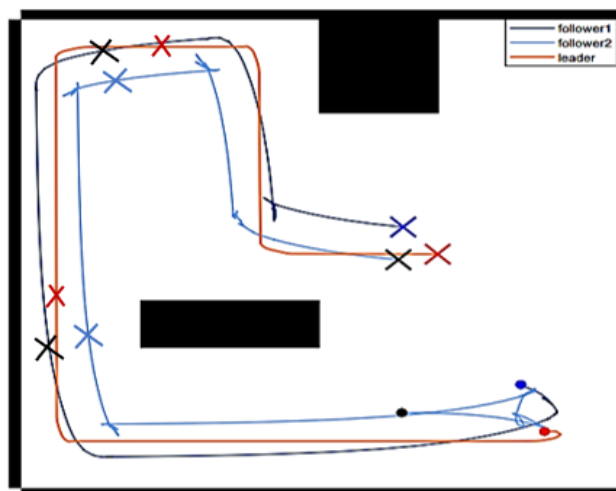

Fig. 9. Simulation of mobile robots' trajectory in a virtual environment without disturbance for followers with PID controller

5- 2- The Second Scenario: FLC without Disturbance

The FLC effectively manages the mobile robots in this scenario under disturbance-free conditions. The error profiles for the $x, y,$ and φ dimensions, as depicted in Figure 10., exhibit slightly improved performance compared to the PID controller. The MSE values for each follower’s orientation are calculated as follows: $MSE\varphi_1=0.0439$ and $MSE\varphi_2=0.0016$. As shown in Figure 11., the FLC excels in providing accurate path tracking, maintaining the desired formation, and avoiding obstacles. Notably, when compared to the PID controller, the FLC demonstrates better performance, especially in corners, where the followers closely follow the leader’s trajectory. Both controllers showcase precise navigation and formation control in this scenario, affirming their potential for practical applications. However, real-world scenarios often introduce disturbances, necessitating further investigations to evaluate their adaptability to specific robotic tasks.

5- 3- The Third Scenario: PID controller with Disturbance

When subjected to external disturbance, the PID controller faced significant challenges in maintaining accurate control of the mobile robots. The disturbance, modeled as a sinusoidal wave with an amplitude of 0.25 and a frequency of 0.4 for follower1, and amplitude of 0.1 and a frequency of 0.4 for follower2, introduced perturbations in the system. As a result, the errors in the $x, y,$ and φ dimensions as shown in Figure 12. and exhibited increased oscillations and deviations from the desired trajectory. The MSE value for each follower’s orientation increased substantially to $MSE\varphi_1=0.1002$, $MSE\varphi_2=0.0365$. The final simulation of the mobile robots’ navigation under the PID controller with disturbance is illustrated in Figure 13. and indicates a notable departure from the desired path, impacting path tracking and formation maintenance. The robots struggled to adapt to the disturbances effectively, leading to deviations and collisions with obstacles. These results underscore the PID controller’s vulnerability to external disturbances.

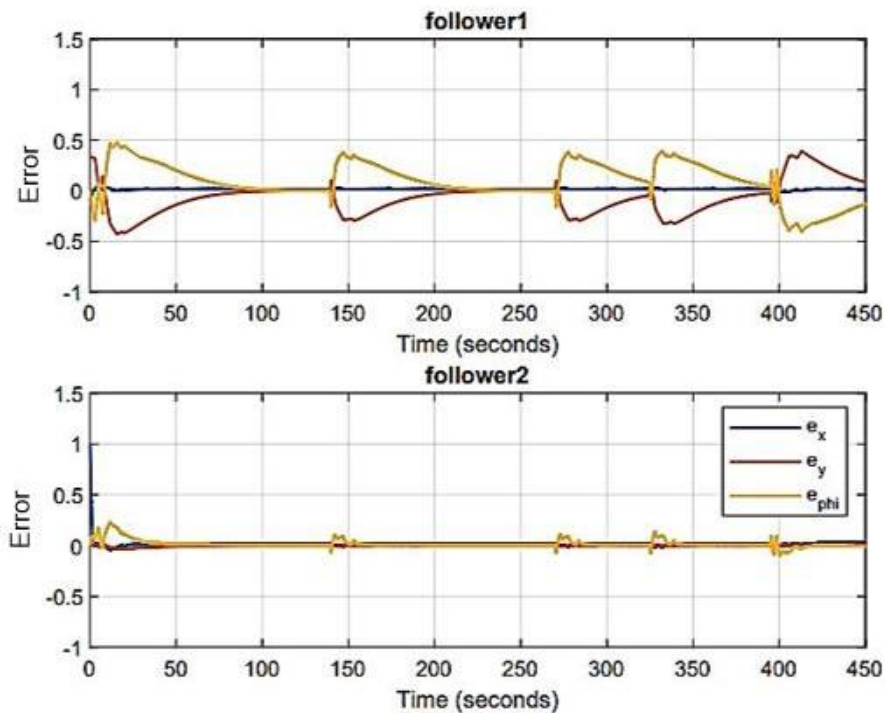

Fig. 10. Position and orientation errors for follower mobile robots with FLC without disturbance

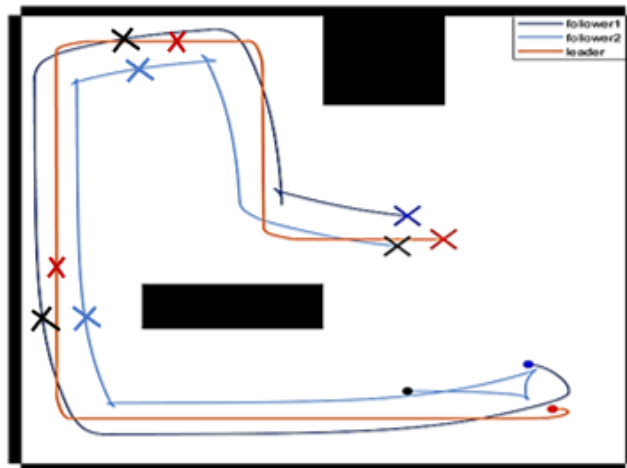

Fig. 11. Simulation of mobile robot's trajectory in a virtual environment without disturbance for followers with fuzzy controller

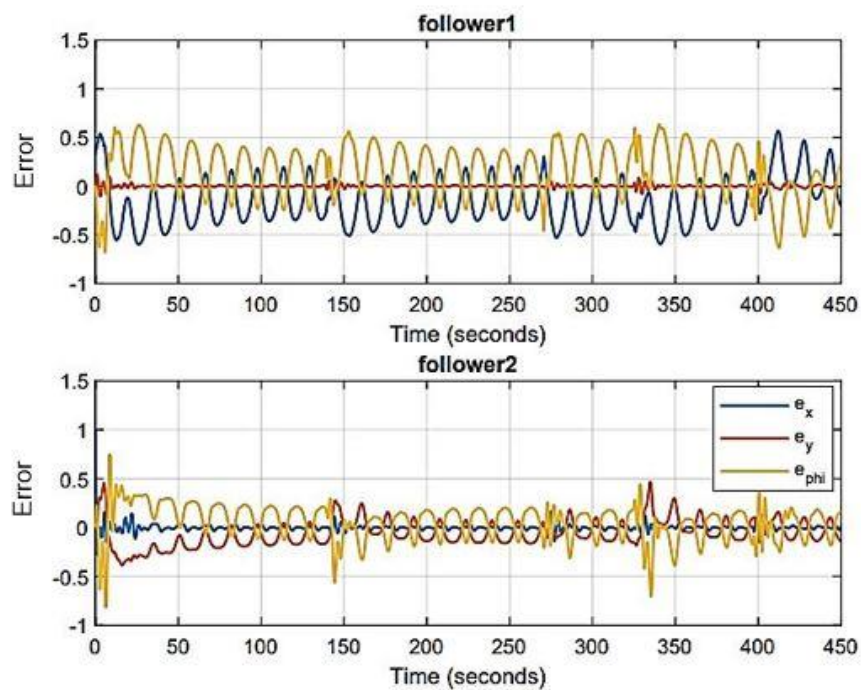

Fig. 12. Position and orientation errors for follower mobile robots with PID with disturbance

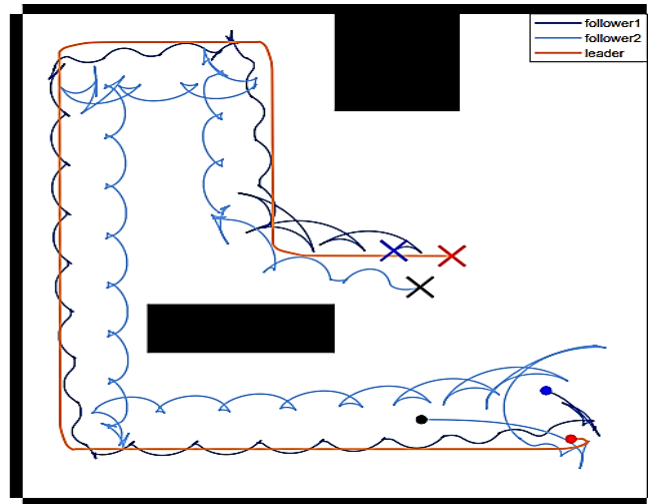

Fig. 13. Simulation of mobile robot's trajectory in a virtual environment with disturbance for followers with PID controller

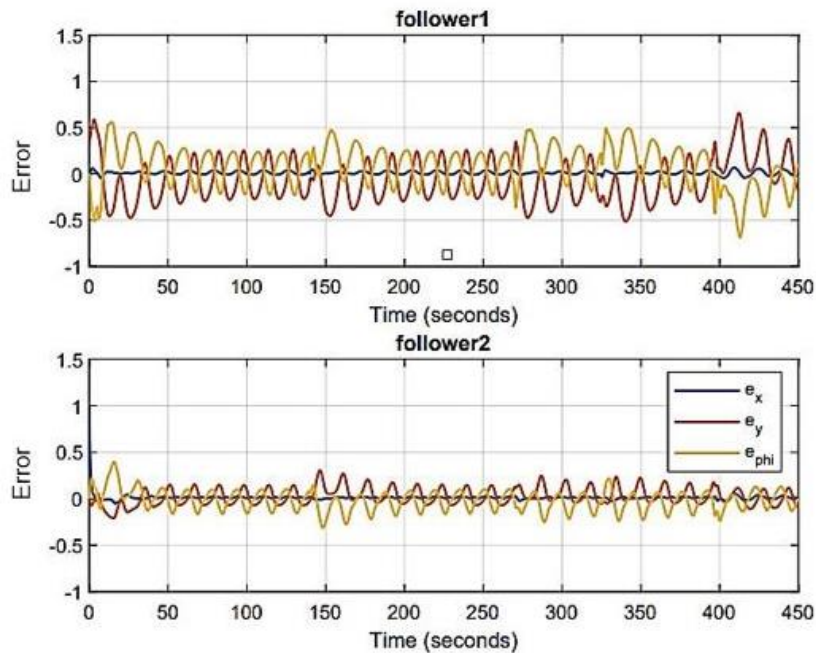

Fig. 14. Position and orientation errors for follower mobile robots with FLC

5- 4- The Fourth Scenario: FLC with Disturbance

In contrast, the FLC demonstrated superior performance in the presence of external disturbances. The same sinusoidal disturbance was applied, with an amplitude of 0.25 and a frequency of 0.4 for follower1, amplitude of 0.1 and a frequency of 0.4 for follower2. However, the FLC effectively maintained control, with minimal deviations observed in the errors for

$x, y,$ and φ , depicted in Figure 14. The MSE value for each follower's orientation remained consistently low at $MSE\varphi_1=0.0571$, $MSE\varphi_2=0.0125$. The final simulation results, as shown in Figure 15., showcased accurate path tracking, formation maintenance, and practical obstacle avoidance. Notably, the FLC's adaptability to disturbances ensured that the robots closely followed the leader's

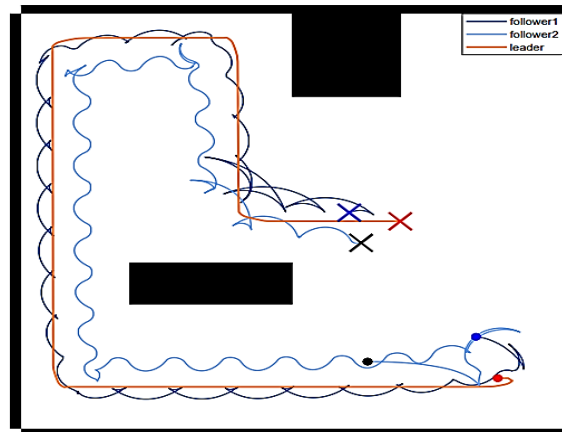

Fig. 15. Simulation of mobile robot's trajectory in a virtual environment with disturbance for followers with fuzzy controller

trajectory, even during abrupt directional changes, such as those in corners. This scenario underscores the evident contrast in performance between the PID controller and the FLC when subjected to disturbances. While the PID controller encountered difficulties maintaining precise control and path tracking, the FLC exhibited remarkable resilience, demonstrating its superiority in disturbance rejection.

6- Conclusion

This study investigates the coordinated movement of mobile robots arranged in a triangular formation, utilizing PID and Fuzzy Logic Controllers (FLC) for trajectory tracking and formation control. Under ideal conditions, both controllers demonstrated precise navigation and formation maintenance. However, introducing external disturbances, represented as sinusoidal waves, revealed a significant contrast in their performance. The FLC showcased remarkable adaptability, maintaining accurate control and path tracking even in disturbances. In contrast, the PID controller struggled to cope with external perturbations, resulting in deviations and collisions. These findings underscore the crucial role of controller selection in practical applications, particularly in environments prone to disturbances. The FLC's ability to effectively handle external perturbations positions it as a robust choice for real-world tasks across various industries. Further research and testing in specific application contexts are recommended to refine controller selection and enhance mobile robot performance in complex and dynamic scenarios.

References

- [1] N. Y. Allagui and N. Derbel, "Fuzzy PI controller for mobile robot navigation and tracking," in 2018 15th International Multi-Conference on Systems, Signals & Devices (SSD), 2018: IEEE, pp. 1178-1183.
- [2] D. Takura and K. Akatsu, "Variable characteristics DC motor by changing brush lead angle to expand the operation range," in 2015 9th International Conference on Power Electronics and ECCE Asia (ICPE-ECCE Asia), 2015: IEEE, pp. 695-700.
- [3] S. Treratanakulchai and J. Suthakorn, "Effective vital sign sensing algorithm and system for autonomous survivor detection in rough-terrain autonomous rescue robots," in 2014 IEEE International Conference on Robotics and Biomimetics (ROBIO 2014), 2014: IEEE, pp. 831-836.
- [4] M. Elsis, and M. Soliman, "Optimal design of robust resilient automatic voltage regulators," *ISA transactions*, vol. 108, pp. 257-268, 2021.
- [5] M. Elsis, "New variable structure control based on different meta-heuristics algorithms for frequency regulation considering nonlinearities effects," *International Transactions on Electrical Energy Systems*, vol. 30, no. 7, p. e12428, 2020.
- [6] M. Elsis, N. Bazmohammadi, J. M. Guerrero, and M. A. Ebrahim, "Energy management of controllable loads in multi-area power systems with wind power penetration based on new supervisor fuzzy nonlinear sliding mode

- control,” *Energy*, vol. 221, p. 119867, 2021.
- [7] M. Elsis, K. Mahmoud, M. Lehtonen, and M. M. Darwish, “Effective nonlinear model predictive control scheme tuned by improved NN for robotic manipulators,” *IEEE Access*, vol. 9, pp. 64278-64290, 2021.
- [8] H. Omrane, M. S. Masmoudi, and M. Masmoudi, “Fuzzy logic based control for autonomous mobile robot navigation,” *Computational intelligence and neuroscience*, vol. 2016, 2016.
- [9] S. Khankalantary, I. Izadi, and F. Sheikholeslam, “Robust ADP-based solution of a class of nonlinear multi-agent systems with input saturation and collision avoidance constraints,” *ISA transactions*, vol. 107, pp. 52-62, 2020.
- [10] S. Zhao, “Affine formation maneuver control of multiagent systems,” *IEEE Transactions on Automatic Control*, vol. 63, no. 12, pp. 4140-4155, 2018.
- [11] N. V. Kumar and C. S. Kumar, “Development of collision free path planning algorithm for warehouse mobile robot,” *Procedia computer science*, vol. 133, pp. 456-463, 2018.
- [12] H. Lee and J. Jeong, “Mobile robot path optimization technique based on reinforcement learning algorithm in warehouse environment,” *Applied sciences*, vol. 11, no. 3, p. 1209, 2021.
- [13] M. H. Ko, B.-S. Ryuh, K. C. Kim, A. Suprem, and N. P. Mahalik, “Autonomous greenhouse mobile robot driving strategies from system integration perspective: Review and application,” *IEEE/ASME Transactions On Mechatronics*, vol. 20, no. 4, pp. 1705-1716, 2014.
- [14] H. Durmuş, E. O. Güneş, M. Kırıcı, and B. B. Üstündağ, “The design of general purpose autonomous agricultural mobile-robot: “AGROBOT”,” in *2015 Fourth International Conference on Agro-Geoinformatics (Agro-geoinformatics)*, 2015: IEEE, pp. 49-53.
- [15] K. Nagatani et al., “Redesign of rescue mobile robot Quince,” in *2011 IEEE international symposium on safety, security, and rescue robotics*, 2011: IEEE, pp. 13-18.
- [16] A. Birk, K. Pathak, S. Schwertfeger, and W. Chonnaparamutt, “The IUB Rugbot: an intelligent, rugged mobile robot for search and rescue operations,” in *IEEE International Workshop on Safety, Security, and Rescue Robotics (SSRR)*. IEEE Press, 2006, vol. 10.
- [17] L. Van Nguyen, S. Gibb, H. X. Pham, and H. M. La, “A mobile robot for automated civil infrastructure inspection and evaluation,” in *2018 IEEE International Symposium on Safety, Security, and Rescue Robotics (SSRR)*, 2018: IEEE, pp. 1-6.
- [18] Q. Lu and Q.-L. Han, “Mobile robot networks for environmental monitoring: A cooperative receding horizon temporal logic control approach,” *IEEE transactions on cybernetics*, vol. 49, no. 2, pp. 698-711, 2018.
- [19] G. Klancar, A. Zdesar, S. Blazic, and I. Skrjanc, *Wheeled mobile robotics: from fundamentals towards autonomous systems*. Butterworth-Heinemann, 2017.
- [20] K. H. Kowdiki, R. K. Barai, and S. Bhattacharya, “Leader-follower formation control using artificial potential functions: A kinematic approach,” in *IEEE-International Conference On Advances In Engineering, Science And Management (ICAESM-2012)*, 2012: IEEE, pp. 500-505.
- [21] H. Takahashi, H. Nishi, and K. Ohnishi, “Autonomous decentralized control for formation of multiple mobile robots considering ability of robot,” *IEEE Transactions on Industrial Electronics*, vol. 51, no. 6, pp. 1272-1279, 2004.
- [22] H. S. Dewang, P. K. Mohanty, and S. Kundu, “A robust path planning for mobile robot using smart particle swarm optimization,” *Procedia computer science*, vol. 133, pp. 290-297, 2018.
- [23] P. Renaud, E. Cervera, and P. Martinet, “Towards a reliable vision-based mobile robot formation control,” in *2004 IEEE/RSJ International Conference on Intelligent Robots and Systems (IROS)*(IEEE Cat. No. 04CH37566), 2004, vol. 4: IEEE, pp. 3176-3181.
- [24] R. Olfati-Saber, “Flocking for multi-agent dynamic systems: Algorithms and theory,” *IEEE Transactions on automatic control*, vol. 51, no. 3, pp. 401-420, 2006.
- [25] F. Morbidi, G. L. Mariottini, and D. Prattichizzo, “Observer design via immersion and invariance for vision-based leader–follower formation control,” *Automatica*, vol. 46, no. 1, pp. 148-154, 2010.
- [26] X. Li, J. Xiao, and Z. Cai, “Backstepping based multiple mobile robots formation control,” in *2005 IEEE/RSJ International Conference on Intelligent Robots and Systems*, 2005: IEEE, pp. 887-892.
- [27] H. Bolandi, M. Rezaei, R. Mohsenipour, H. Nemati, and S. M. Smailzadeh, “Attitude control of a quadrotor with optimized PID controller,” 2013.
- [28] M. Mucientes, D. L. Moreno, A. Bugarín, and S. Barro, “Design of a fuzzy controller in mobile robotics using genetic algorithms,” *Applied Soft Computing*, vol. 7, no. 2, pp. 540-546, 2007.
- [29] A. Ghanbarzadeh and E. Najafi, “Design of an optimized fuzzy controller for a 3r non-planar robotic manipulator,” in *2021 9th RSI International Conference on Robotics and Mechatronics (ICRoM)*, 2021: IEEE, pp. 287-292.

HOW TO CITE THIS ARTICLE

S. M. Zakipour Bahambari, S. Khankalantary. *Trajectory Tracking and Formation Control of Mobile Robots Using Fuzzy Logic Controller with Obstacle Avoidance.* *AUT J. Elec. Eng.*, 57(1) (2025) 55-70.

DOI: [10.22060/ej.2024.23254.5596](https://doi.org/10.22060/ej.2024.23254.5596)

